

STAR-33

GPS Engine Module



C O N T E N T S

1. Hardware Specification	-2
1.1 Technical Specification	-2
1.2 Physical Specification	-3
1.3 Recommend PCB Layout	-3
2. Module Pin Assignments and Description Table	-4
3. Electrical Specifications	-6
3.1. Absolute Maximum Ratings	-6
4. Application Schematics	-7
5. NMEA-0183 Output Message	-7

1. Hardware Specification

1.1 Technical Specification

- DGPS & SBAS (WAAS/EGNOS/MSAS)
- GPS L1(1575.42MHz), C/A code
- 48 acquisition & 12 tracking channels
- Up to 60,000 simultaneous search windows
- Easy to integrate,
 - Dual UART data interface
 - Numerous GPIO
- System specification

Typical receiver performance characteristics are presented in the following table.

General	Receiver Architecture	12 Parallel Channels, C/A L1(1575.42MHz)
Sensitivity	Autonomous Tracking	-161dBm
Time to Fix	Outdoor: Cold / Warm / Hot	35s / 32s / 3s typical
	Deep Indoor	<20 s typical
Accuracy	Position	2m CEP
	Velocity	0.1 m/s
	Position-Indoor	Far exceeds E911 requirements
Interfaces	Protocols	▪ NMEA 0183 Ver3
	1PPS Timing Output	<20 ns resolution
	External Event Input	<20 ns resolution
	Max Velocity / Altitude	515 m/s 18,000m (increased rating version available subject to export license)
	Max Acceleration / Jerk	4g / 1g /s
	DGPS and WAAS Capable	▪ DGPS & SBAS (WAAS/EGNOS/MSAS)

1.2 Physical Specification

- Size & Volume : 13(w) x 15(d) x 2.2(h)mm

1.3 Recommend PCB Layout

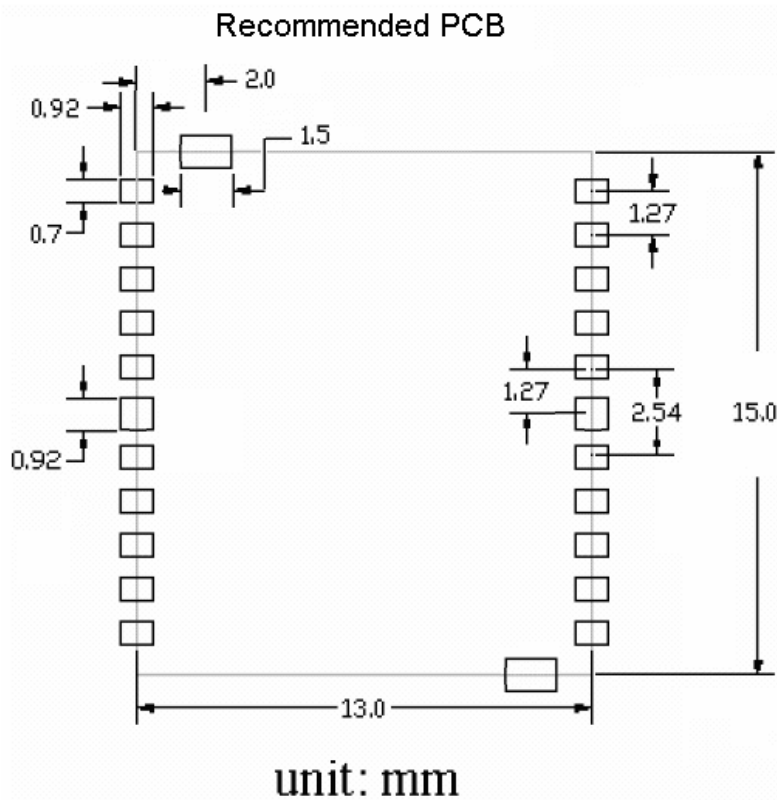

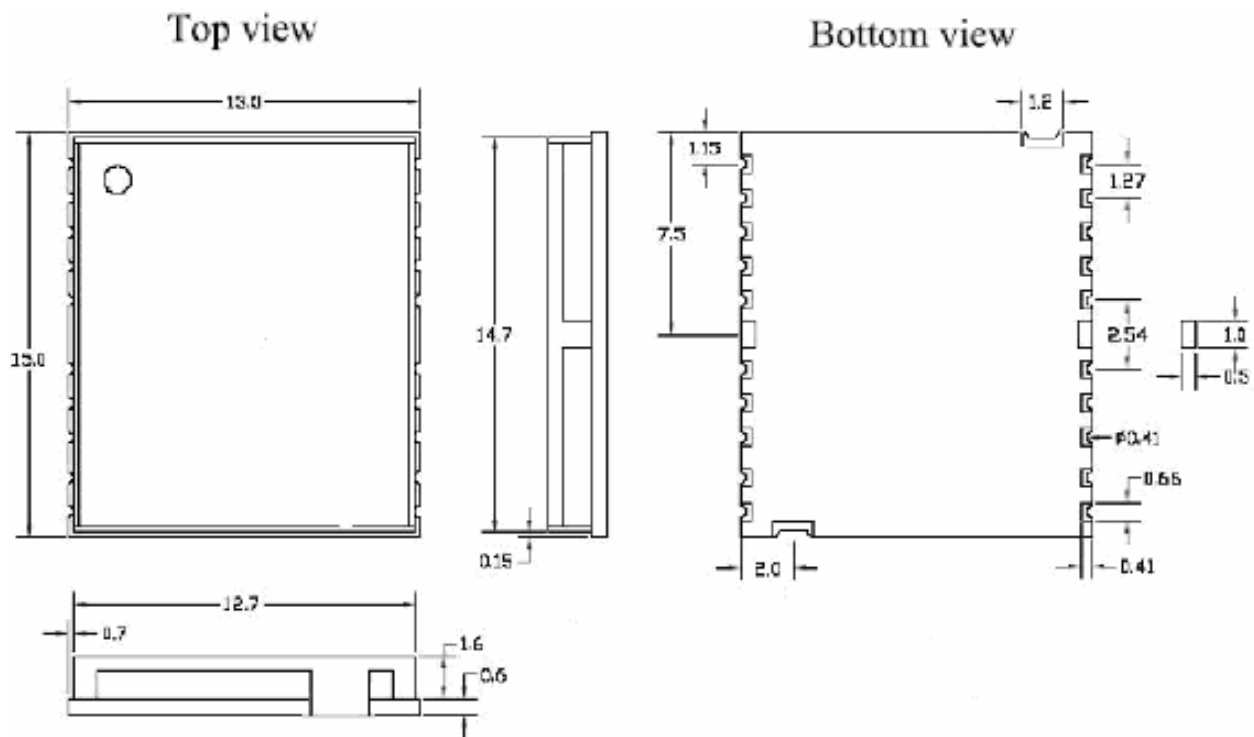

2. Module Pin Assignments and Description Table

1	RX0	GND	20
2	TX0	RF_IN	19
3	1PPS	GND	18
4	TX1	V_ANT	17
5	RX1	NC	16
21	GND	GND	22
6	GPIO5	GPIO3	15
7	GPIO2	TAID	14
8	GPIO7	WAKEUP	13
9	VOUT	VIN	12
10	ON_OFF	V_RTC	11

Top view

Pin	Name	I/O	Function
1	RX0	Input	Serial data input 0 (receive data)
2	TX0	Output	Serial data output 0 (transmit data)
3	1PPS	Output	Synchronize with GPS time
4	TX1	Output	Serial data output 1 (transmit data)
5	RX1	Input	Serial data input 1(receive data)
6	GPIO5	I/O	General purpose I/O control pin (If no use, keep floating)
7	GPIO2	I/O	General purpose I/O control pin (If no use, keep floating)
8	GPIO7	I/O	General purpose I/O control pin (If no use, keep floating)
9	VOUT	Output	Module power on indicate, 2.8V output
10	ON_OFF	Input	Control module on/off, Low active (turn off module power supply)
11	V_RTC	Input	RTC DC power input (input voltage 2.2~6V)
12	VIN	Input	DC power (input voltage 3.2~5V)
13	WAKEUP	Input	Wakeup GPS module from suspend mode (Low to wakeup and high to suspend)
14	TAID	Input	AGPS mode support (Time Aiding from cell phone system)
15	GPIO3	I/O	General purpose I/O control pin (If no use, keep floating)
16	NC	N/A	
17	V_ANT	Output	2.8V RF power output for active antenna
18	GND	N/A	Ground
19	RF_IN	Input	GPS RF signal input
20	GND	N/A	Ground
21	GND	N/A	Ground
22	GND	N/A	Ground

(1) Ground pins

Pin18, 20, 21, 22 are module ground pins. Bigger ground planes and more ground vias around the pins is important to minimize the interference.

Pin SGND is for shielding ground. Connect these two pins together with other ground pins. Bigger ground planes and more ground vias around the pins is important to minimize the interference.

(2) RF input

The GPS module input is optimized to connect to a 50 ohm antenna. The minimized noise figure is achieved by -10dB input return loss. Well controlled antenna impedance (as close to 50ohm as possible) remains the stable system sensitivity. Do not try to match the GPS

module to 50ohm for lower return loss which might induce the noise figure increased.

This is reserved for a non-50ohm antenna. For an application of 50ohm antenna, The impedance of RF traces between GPS module, π matching network, and antenna has be controlled in 50ohm +/-10%. The tight ground vias surround the RF traces is benefit to isolate noise out.

(3) Active antenna DC power

The module has a built-in LNA, the applications for passive antenna performs well as active antenna with short RF traces between antenna and module (the path loss between the passive antenna and module induces the same degradation of system sensitivity directly).

(4) Power supply

3.2V ~ 5V is acceptable operation range of main power supply. The DC power ripple is required for less than 50mVpp.

(5) RTC power backup

2.2V ~ 6V is acceptable operation range of main power supply. The DC power ripple is required for less than 50mVpp.

3. Electrical Specifications

3.1. Absolute Maximum Ratings

Warning – Stressing the device beyond the “Absolute Maximum Ratings” may cause permanent damage. These are stress ratings only. Operation beyond “Operating conditions” is not recommended and extended exposure beyond the “Operating condition” may affect device reliability. This module is not protected against over voltage, reversed voltage or short current of RF_IN port.

Parameter	Min	Max	Unit
Power supply voltage(VCC)	3.2	5.0	V
Serial port input voltage	-0.3	5.0	V
BOOTSEL input voltage	-0.3	3.6	V
Storage temperature	-40	125	

4. Application Schematics

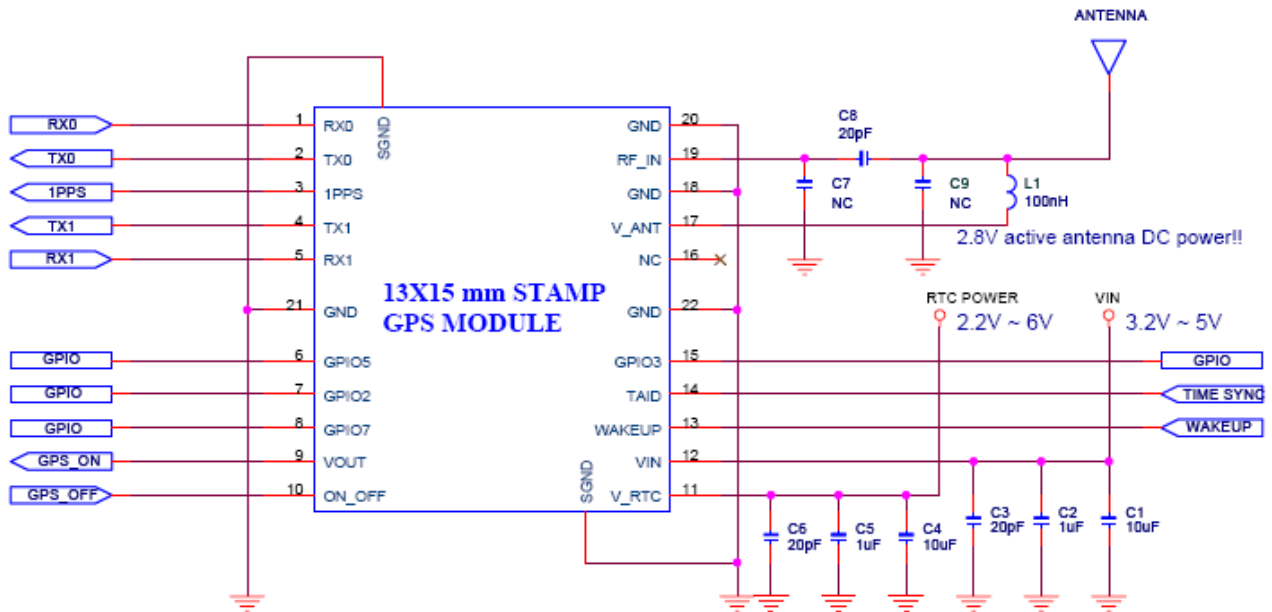

5. NMEA-0183 Output Message

Its output signal level is TTL: 9600bps (default), 8 bit data, 1 stop bit and no parity. It supports NMEA-0183 V3.0

Protocol and the following

Messages: GGA, GSA, GSV and RMC.

The following is written assuming the user has a basic understanding of NMEA protocols and their use.

NMEA Output messages

NMEA	Record Description
GGA	Global positioning system fixed data
GSA	GNSS DOP and active satellites
GSV	GNSS satellites in view
RMC	Recommended minimum specific GNSS data