

Satellite Radio Antenna SRA-12



SPECIFICATION FOR SDARS ANTENNA WITH LOW NOISE AMPLIFIER

CAUTIONS

SRA-12 is specific for the Satellite Digital Audio Radio System (SDARS) application.

1. Products such as motors, computer, and RF devices, which emit high power of magnetic field and interference, that may cause the performance of the antenna unit to drop.

2. The optimal position for automobile applications is on the top of roof of the vehicles.

If the antenna unit is to be placed inside the car, be certain to avoid coverage by metal objects for optimal performance.

1.0 SYSTEM

This antenna system consists of two functional blocks, the LNA portion and the antenna element.

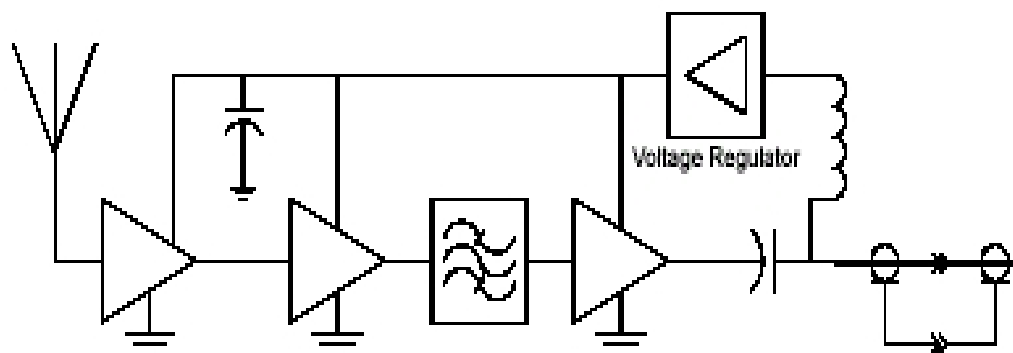

Fig. 1

2.0 ENVIRONMENTAL CONDITIONS

2.1 Operation Temperature	-40 to + 85
2.2 Storage Temperature	-40 to + 100
2.3 Relative Humidity	5% to 95%

3.0 ELECTRICAL SPECIFICATIONS	
3.1 Operation Voltage	Min: 3.6V Typ: 4.7V Max: 5.5V
3.2 Power Consumption	@ 4.7V Typ: 45mA Max: 60mA

4.0 MECHANICAL SPECIFICATIONS	
4.1 Mounting	Magnet mount
4.2 Horizontal Pulling Force of Magnet	1.5 Kg Min.
4.3 Water Proof	Deep into water 1M 1Hr.
4.4 Shock	10msec. Half sine wave.
4.5 Vibration	10~200Hz Log. Sweep 3.0G sweep time: 15 Minutes, 3 Axes.
4.6 Magnet Threshold	The antenna must stay attached to the vehicle, at a speed of 180 km/h.
4.7 Cable Pulling Off Force	At room temperature Min 5Kg /10sec. Apply 5Kg /10sec pulling force between the cable and the antenna unit, no visible damage shall appear on the cable and connector.
4.8 Bending Test	After bending 90° right and left for 1,000 cycles, no permanent damage were found.
4.9 Weight	80g Max.
4.10 Dimension	See Fig. 2

5.0 ANTENNA ELEMENT				
5.1 Frequency Range		2338.75 ± 6.25 MHz.		
5.2 Polarization		LHCP		
5.3 Bandwidth		50MHz min (Return Loss -10 dB)		
5.4 Gain at Zenith		+5.0 dBic typ		
5.5 Axial Ration (at Zenith)		3.0dB max		
5.6	Passive gains	Elevation Angle, Θ (deg)	Minimum Gain	Average Gain
		20	+0.5dBic	+2dBic
		25	+1dBic	+2dBic
		30 $\leq\Theta\leq$ 60	+2dBic	+2dBic
		0		-2dBic
Condition: With 50mm square ground plane				

6.0 LNA	
6.1 Frequency Range	2338.75 ± 6.25 MHz
6.2 LNA Gain	Min:30dB Typ:33dB (25 ± 5 Without cable)
6.3 Noise Figure	Typ. 0.8 dB / Max. 1.0 dB (+25 ± 5) 1.4 dB Max (+85)
6.4 Filter attenuation at 2338.75 ± 230MHz	> 25 dB

6.5 Interfering P1dB at 1850-1990MHz	> - 10 dB
6.6 Interfering P1dB at 824~894MHz	> - 4 dB
6.7 Interfering P1dB at 450MHz	> 0 dB
6.8 ESD	Antenna surface \pm 15KV / Connector pin \pm 8KV

7.0 OUTLINE

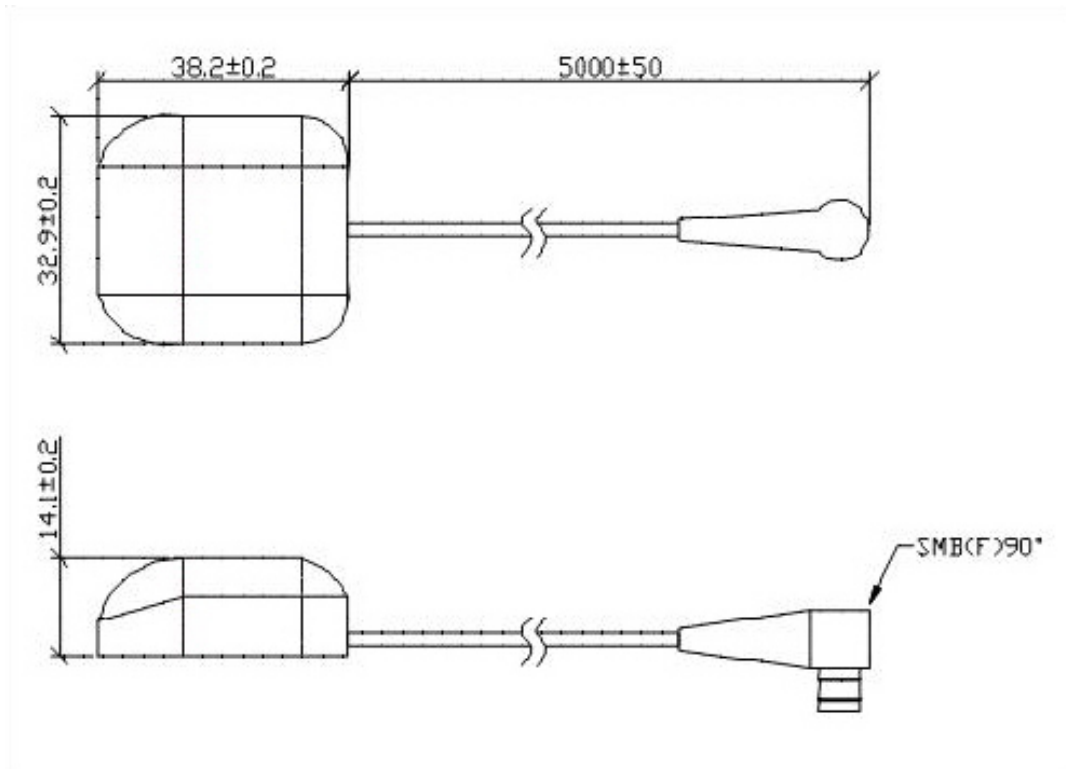

Fig 2.